

KLEPELMAAIER **KL 102**

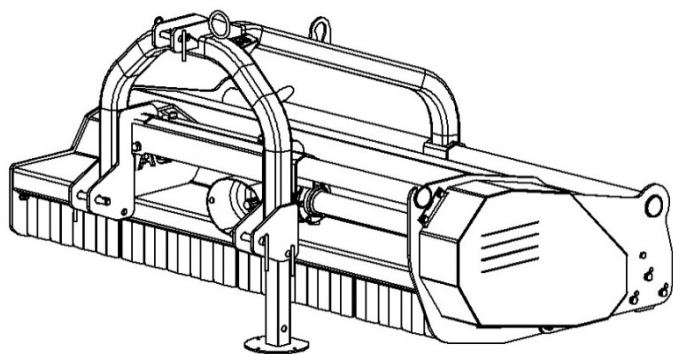



standaard machine

- * lage bouwvorm
- * rotor \varnothing 180 mm met asuiteinden \varnothing 50 mm
- * buiten diameter klepelas \varnothing 440 mm
- * hoog toerental van klepelas
- * chassis voorzien van inwendig weerhaken
- * automatische riemspanner
- * voorzien van 4 of 5 spb-riemen afh. Werkbreedte
- * man. in verstek te plaatsen met lineaire geleiding
- * standaard aanhang cat II , \varnothing 28 mm
- * haakse tandwielkast 540 tr/min
- * zware klepel 2,2 kg met bevestigingsbout M20
- * inclusief kardanas

verkrijgbaar in verschillende werkbreedtes

art. nr.	type-model	werkbr. cm	totale br. cm	klepels #	V-riemen #	gewicht kg	prijs €
160-002-140	KL140-102	145	165	10	3		
160-002-160	KL160-102	165	185	10	4		
160-002-180	KL180-102	185	205	12	4	630	
160-002-200	KL200-102	205	230	12	5	690	
160-002-220	KL220-102	225	250	14	5		
160-002-240	KL240-102	245	270	14	5		

optie

160-095-001	1	sledes				
160-095-003	2	hydraulische cilinder voor verstek				
150-001-001	3	hydraulische poetser aan klepelmaaier				
160-095-005	4	looprol \varnothing 220				