

## PULVERISER **KL 110**

### standard machine

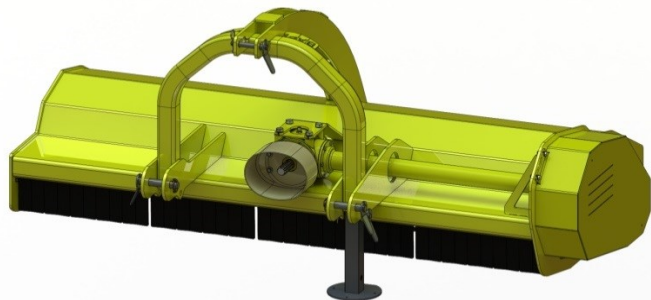

- \* low profile design , rear mounted
- \*  $\varnothing$  180 mm rotor tube with shaft ends  $\varnothing$  50 mm
- \* outside diameter flails 440 mm
- \* high speed rotor
- \* chassis 6/10 mm with internal hooks
- \* automatic belt tensioner
- \* 4 or 5 V-belts SPB section depending on cutting size
- \* 3-point linkage cat II ,  $\varnothing$  28/25 mm
- \* gearbox 540 rpm
- \* heavy duty flail 2,2 kg with fixing bolt M20
- \* included drive-shaft
- \* rear roller  $\varnothing$  140 mm

different models available

art. nr.	type-model	cutting cm	total width cm	flails #	V-belts #	weight kg	price €
160-010-140	<b>KL140-110</b>	145	165	10	3		
160-010-160	<b>KL160-110</b>	165	185	10	4		
160-010-180	<b>KL180-110</b>	185	205	12	4	630	
160-010-200	<b>KL200-110</b>	205	230	12	5	690	
160-010-220	<b>KL220-110</b>	225	250	14	5		
160-010-240	<b>KL240-110</b>	245	270	14	5		

### options

160-095-001      1      skids



160-095-005      2      rear roller  $\varnothing$  220

