

## BIN TRANSPORTER

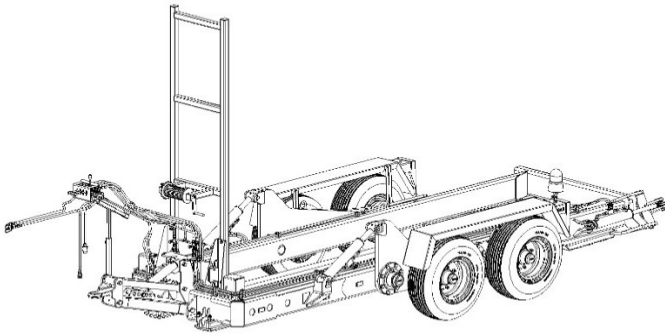

### **standard machine**

- wheels:** 4x 11,5/80x15,3 AS farmer 14 ply  
**axle:** tandem axle  
each axle (square 80 mm) with brake 300 x 90 mm  
rim connection:  $\varnothing$  160 x  $\varnothing$  205 6 bolts  
brake activated with mineral oil from brake valve of tractor
- capacity:** 7 tons
- dimension:** internal: width 1300 mm  
length 5100 mm
- lights:** for road traffic  
working lights 2x
- control:** manuele valveblock (4 function)

### **options**

- wheels:** 4x 245/70 R175 (heavy duty lorry wheels)
- brake:** controlled by air
- side wall:** for support of bins left and right , hydraulic controlled
- length:** different length